

CUTLAM[®]4.0

High-capacity automatic cutting machine

The CUTLAM[®]4.0 is designed especially for manufacturing companies with high standards who are looking for high-quality and reliable equipment for heavy-duty use with a great cutting capacity.

La CUTLAM[®]4.0 is a pedestal-mounted single-block machine with an integrated recirculation/decanter tank. The wheel's vertical descent can be controlled automatically (oleo pneumatic) or manually using the joystick. The maximum cutting descent is 240 mm.

Adapted for intensive use on heavy components, the CUTLAM[®]4.0 is fitted with a powerful 5.5 kW motor.

The wheel's speed is adjustable from 1000 to 4000 rpm, the feed speed is adjustable. **2 cutting modes are available:** sequential automatic with adjustable frequency or continuous.

An end of cycle sensor shuts off the machine and automatically raises the wheel after each operation.

The controls are easy to use and intuitive: they are centralized on the 5.7" arm-mounted touch-screen.

The wide cast-iron clamp bench has 6 T-longitudinal grooves and 5 transversal grooves, and as an optional extra may be made mobile along the X and the A axes.

The cover opening clears 3 sides, guaranteeing easy loading of heavy or bulky parts. Removable gates to the left and right enable you to cut long bars.

/ Technical Data

Wheel Ø	300 to 400 mm
Shaft Ø	25,4 mm
Standard flanges Ø	100 mm
Max cutting capacity	Ø 154 mm or 145 x 160 mm or 90 x 275 mm (with a Ø 400 mm wheel) + right and left opening for long parts)
Passage under the wheel	190 mm (with a Ø 400 mm wheel)
Vertical movement	Manual
Lubrication	Recirculation system, 140 litres, on casters Cleaning system integrated, with a shower head outside of the cutting chamber
Motor power	5,5 kW
Rotational speed	Variable, from 1000 to 4000 rpm
Arm speed advance	5 to 200 mm/min during cutting
Table	Double grooved treated cast iron, 400 x 400 mm
Type of groove	T groove 12 mm (6 longitudinal, 5 transversal)
Lightening	LED
Protection	Cover with locking system
Body	Steel coated with epoxy paint
Pneumatic feeding compressed air	6 bars filtered 5 µ
Electrical power	6 kW cumulative
Electrical consumption	24 Ah
Voltage	400 Volts - 50 Hz (three-phase)
Dim. W x H x D	818 (+ 300 mm with control panel) x 1802 x 1280 mm
Weight	650 kg
Reference	60 CT40A 00



CUTLAM[®]4.0 - Ø 400 mm

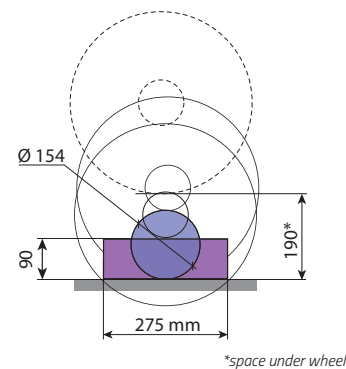

The multi-point hose over the wheel and part ensures optimum cooling for high-quality cuts and consistent results.

In the standard configuration, the work area is illuminated by a adjustable spotlight, and an external shower head is provided for cleaning the cutting area.

In order to optimise your equipment according to your needs, a variety of accessories and optional extras are available.

/ Accessories

Independent double vice (right and left) with fast tightening system	60 CT400 20
Universal clamping KOPAL 61	60 08128220

/ Options

Table with manual longitudinal displacement (Y axis) of a 180 mm stroke	60 CT401 00
Table with manual transversal displacement (X axis) of a 120 mm stroke	60 CT402 00
Positioning laser	60 CT403 00

High-capacity automatic cutting machine Ø 400 mm



Integretade cooling tank



ESSENTIALS



Double vice with fast tightening system



Double vice with screw tightening system



Universal clamping KOPAL 61

ACCESSORIES

Manual cross-feed table (X axis)

Manuel mouvement (Y axis)

CONSUMABLES



Cut-off wheels Ø 400 mm, High performance, precision and diamond



Cutting fluid 721