

CUTLAM[®]5.0

High-capacity 2 or 3 axes programmable automatic cutting machine

The CUTLAM[®]5.0 is a pedestal-mounted machine with an integrated recirculation/decanter tank. It represents the ultimate equipment in terms of high-capacity programmable automatic cutting machines. Power and advanced control of the cutting steps will guarantee first class efficiency and productivity.

/ Wheel and table movements

Fitted in standard with a Ø 355 mm wheel, which produces an automatic vertical and longitudinal movement. The automatic transverse movement is carried out by an optional cross-feed table.

/ Controls

Programming is performed via a large touch screen with a graphical interface that ensures you an intuitive use. Cutting parameters are continuously visible on the screen. Fast positioning of the cutting point is provided by the use of a joystick.

The internal memory allows you to store 300 programs that can be transferred via USB.



A spacious cutting chamber: W 408 x D 422 mm with openings on both right and left sides for the cutting of long samples.

/ Easy programming

Depending on the location of the sample on the table, and on its dimensions, the screen will indicate the various necessary and possible moves in order to complete the cut. This data can then be saved.

/ All cutting modes are possible

- Automatic or manual cutting.
- Continuous automatic cutting with ingenious feed speed control:
 - The feed speed is pre-set, and will be automatically reduced if the load on the cutting wheel increases. The pre-set speed returns when the load on the screen decreases.
 - It improves the quality of the cut by limiting the thermal damages over the samples.
 - It is suitable for irregular samples and/or material with heterogeneous hardness.
 - It prevents the wheel from breaking in case of overload.
 - It allows you to work at maximum speed without any risk of damage.
- Automatic sequential cutting for maximum cooling.
- Plunge cutting, horizontal feed cutting and oscillating cutting.
- Repetitive parallel cutting.

/ Equipments

A high-capacity, independent cooling/recirculation system (140 litres) is located under the machine. The multipoint nozzles insure excellent cooling of the sample and the cutting wheel even during intensive use.

Fast cleaning is made possible thanks to an exterior shower head and a carefully designed cutting chamber.

The wide cutting table: W 408 x D 422 mm is composed of two independent parts. 4 longitudinal grooves and 6 transversal grooves that allow to fix all kind of clamping systems available as options or on the market.

CUTLAM®5.0 - Ø 355 mm

Theoretical cutting capacity

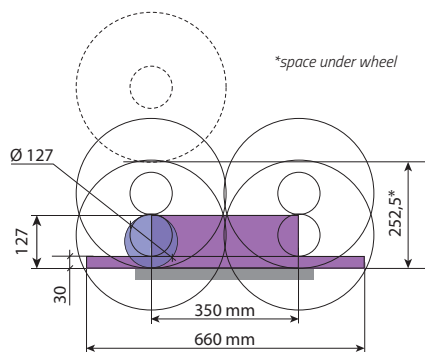

Work area lit by LED strip

/ Technical Data

Wheel Ø	355 mm (400 mm optional)
Shaft Ø	25,4 mm
Standard flanges Ø	100 mm
Max cutting capacity	Ø 127 mm (with Ø 355 mm wheel) + opening on left and right hand side for long parts
Passage under the wheel	252,5 mm (Ø 355 mm wheel)
Vertical movement	Z axis stroke 350 mm, speed from 0,1 to 25 mm/sec, speed advanced 50 mm/sec
Longitudinal movement	Y axis stroke 350 mm speed from 0,1 to 25 mm/sec advanced speed 50 mm/sec
Transversal movement	X axis stroke 120 mm (optional)
Lubrication	Recirculation system, 140 litres, on casters Cleaning system integrated, with a shower head outside of the cutting chamber
Motor power	5,5 kW
Rotational speed	Variable, from 1000 to 4000 rpm
Table	Treated aluminium and interchangeable stainless steel plate, W 408 x D 422 mm
Type of groove	T-slots 12 mm (4 longitudinal, 6 transversal)
Lightening	LED strip
Protection	Cover with locking system
Body	Steel coated with epoxy paint
Pneumatic feeding	6 bars filtered 5 µ
Electrical power	12 kW combined
Electrical consumption	32 Ah
Voltage	400 Volts - 50 Hz (three-phase + ground)
Dim. W x H x D	877 (+ 600 mm with control panel) x 1727 x 1800 mm (H. cover open 2272 mm)
Weight	750 kg
Reference	60 CT50A 00

/ Accessories

Independent double vice (right and left) with fast tightening system, medium size	60 CT400 20
Universal clamping vice 61	60 08128220

/ Options

Motorised cross-feed table (X axis) stroke 120 mm, accuracy 0,05 mm	60 CT501 00
Machine for cut-off wheel Ø 400 mm	60 CT503 00



60 CT503 00



60 CT501 00



60 08128220



60 CT400 20