

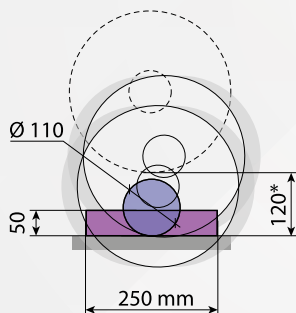

CUTLAM[®]1.1

 Manual cutting machine
 vertical motion

Theoretical cutting capacity - Ø 305 mm
**space under wheel*

CUTLAM[®]1.1

MADE IN FRANCE

The CUTLAM[®]1.1 is a bench-mounted cutting machine for a wide range of applications. Robust and easy to use, with a deported motor design, this machine has a very large cutting capacity. It allows you to equip your laboratory with a simple, versatile and reasonably-priced machine made from high-quality components.

This machine offers a spacious cutting table, made of treated anti corrosive cast iron. It is also easy to handle with a fully opening cover and remote motor. The 4 perpendicular grooves enable you to clamp components of thicknesses up to 120 mm. The CUTLAM[®]1.1 can be equipped with Ø 250 to 305 mm cut-off wheels.

Fitted with a speed adjuster and a powerful 3.8 Kw motor particularly adapted to Ø 305 mm wheels, the CUTLAM[®]1.1 is perfect for intensive use.

The high-capacity recirculation system with pre-filter and de-canter compartments ensures optimum lubrication and cooling by a multi-point spray.

The cutting chamber is illuminated by a strong and trendy aluminium projector.

The protection cover is made of two parts: a large glass area, giving a complete visibility on the cutting chamber, and a lacquered metallic belt offering a high resistance to this protection core. Furthermore, thanks to an interlocking system, this cover locks itself when the wheel is in rotation.

This machine is offering 2 lateral openings, giving the possibility of cutting bars which have a 60 mm diameter.

An external shower head combined with a tilted cutting chamber base makes cleaning easy, and an inlet filter ensures that your samples do not fall down the large-diameter outlet pipe.

Technical Data	CUTLAM [®] 1.1
Wheel Ø	250-305 mm
Shaft Ø	25,4 mm
Standard flanges Ø	80 mm
Max cutting capacity	Ø 110 mm (Ø 305 mm wheel)
Passage under the wheel	120 mm (Ø 305 mm wheel)
Vertical movement	Manual
Lubrication	Recirculation system, 60 litres, on casters, integrated cleaning system, with shower head located outside the cutting chamber
Motor power	3,8 kW
Rotational speed	Variable, from 1000 to 4000 rpm
Table	Groove treated stainless steel, 400 x 300 mm
Type of groove	T groove 12 mm (2 longitudinals, 2 transversals)
Lightening	LED
Protection	Transparent cover with locking system
Body	Epoxy painted coated steel
Voltage	400 Volts - 50 Hz (three-phase)
Dim. W x H x D	630 x 650 x 820 mm - H opened cover: 820 mm
Weight	125 kg
Reference	60 CT110 00

CUTTING MACHINES

Example of application: cutting of a sphere

One of the recurrent issues remaining in the cutting processes is the clamping of spherical parts. The implementation of this kind of vice on the CUTLAM® 1.1 enables to cut spheres having a diameter going from 30 mm to 60 mm.

**Example of application: cutting of a glass cylinder with double wheel**

Tooling allowing the removal of a 3 mm slice from a glass cylinder Ø 50 mm, height 50 mm. This article includes the supply and installation of a specific clamp and a double grinding wheel on a CUTLAM® 1.1 machine.

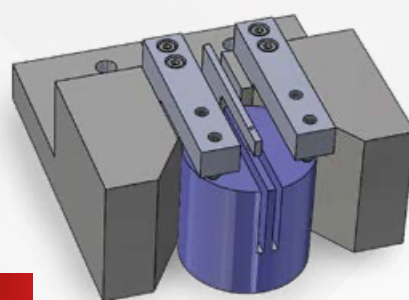

NEW

Accessories

Fast tightening double vice system	60 CT200 20
Screw tightening double vice system	60 CT200 40
Universal clamping vice KOPAL 61	60 081282 20
Clamping flange adjustment	60 081282 40
Long shaft for clamping flange KOPAL	60 00285 90
Cabinet: 1 drawer, 1 storage + integration of the recirculation tank	60 M0100 00
Universal table (X axis) for parallel cuttings	60 CT205 20
Stainless steel table in option	60 CT211 200
Aspiration/filtration set (see specific page)	60 CT204 00



60 081282 40



60 00285 90



60 081282 20



60 CT206 20



60 CTC20 520



Recirculation system 60 L



60 CT200 40



60 CT200 20



Interlocking

CUTLAM® support cabinet

Solid painted-steel piece of furniture specially designed for CUTLAM® products.

It contains a storage door for tools and cut-off wheels, a drawer on top and a space for the recirculation tank. This piece of furniture is stable and has adjustable feet.

For CUTLAM® micro 3.0 and CUTLAM® 1.1
Dimensions W x H x D: 630 x 800 x 835 mm.
Reference: 60 M0100 00

For CUTLAM® 3.1
Dimensions W x H x D: 700 x 800 x 1050 mm.
Reference: 60 M0310 00

